

## ONE SERIES SAFETY TRANSMITTER PRESSURE AND TEMPERATURE TRANSMITTER-SWITCH



- **Improve Availability** with reduced nuisance trips
- **Improve Uptime** with safety diagnostics
- **Improve Safety** with Safety Relay Output to ensure safety function
- **Lower Inventory** a transmitter, switch and gauge in one
- **Simplify Complex Safety Systems** with SFF = 98.8%
- **Reduce Migration Costs** with backward and forward compatibility
- **Certified for Use** in SIL 2 functional safety systems per IEC 61508:2010



## OVERVIEW

The One Series Safety Transmitter is a transmitter-switch for monitoring pressure or temperature and meets the requirements of SIL 2 for random integrity at HFT = 0, SIL 3 for random integrity at HFT = 1 and SIL 3 for systematic capability. The One Series Safety Transmitter incorporates UE's patented IAW self diagnostics, redundant and diverse signal processing and software algorithms to detect abnormalities in the process and internal faults. The design is based on a powerful microprocessor that provides an extremely fast response time for emergency shutdown situations.

Some applications require a local switch that is capable of initiating an emergency shutdown at the point of measure. This avoids any time lag that may occur by sending a signal to a safety PLC and having the PLC initiate the shutdown. This practice can take several (precious) milliseconds. Unique to UE One Series transmitters, the One Series Safety Transmitter can provide the shutdown directly in less than 100 milliseconds, ideal for positive displacement pump applications (for example). This high-capacity safety relay output (SRO) with programmable set point and deadband, handles high voltages and current to actuate a control valve or shut down a compressor directly and rapidly, something a transmitter alone cannot do.

UE is aware that not all Safety Instrumented System (SIS) applications require an emergency shutdown when abnormal conditions are detected. For this reason, the One Series Safety Transmitter provides additional logic outputs for use in voting logic schemes that may be used to report warnings prior to a shutdown. This feature provides the SIS design engineers with the ability to balance the need to provide a safe working environment with the need to keep the process running - but only if conditions permit it.

The combination of features like no moving parts and IAW (I Am Working) self-diagnostics provide a highly reliable, accurate and repeatable monitor for detecting pressure and temperature process variables and making intelligent switch decisions based on retained settings and the process conditions. The IAW feature provides a solution to the "blind device" issue common with mechanical apparatus. The health status of the One Series Safety Transmitter is communicated via the display, 4-20 mA analog signal and IAW status outputs. If a fault is detected, the 4-20 mA signal will output  $\leq 3.6$  mA, compliant to the NAMUR NE 43 standard. Simultaneously, the IAW status signal will change state. By monitoring both signals, redundant methods of fault detection are provided, independent of the process variable.

The One Series Safety Transmitter provides an explosion-proof type 4X/IP66, weather-tight enclosure suitable for harsh environments and hazardous (Class I, Division 1, Zone 1) locations and allowing the One Series Safety Transmitter to be mounted outside. Repeatability of 0.1% of maximum range rivals transmitters that cost much more than the One Series Safety Transmitter. Combined, these features provide an extremely accurate Safety Relay Output (SRO) set point that will not drift over time.

Model 2SLP is loop-powered and operates in a transmitter loop attached to an analog PLC or DCS input and provides a field-scalable 4-20 mA signal over a 2-wire connection. Model 2SLP contains a high-capacity solid-state relay switch (SRO) with various options for high and low AC & DC voltages. See page 8 for details.

The set point and deadband (hysteresis) of the Safety Relay Output is fully programmable over the entire range of the sensor. Reaction time for the One Series Safety Transmitter to a process change is less than 100 milliseconds - switch outputs only with Filter set to "OFF".

## FEATURES

- Digital process display
- Programmable set point and deadband
- Self-diagnostic solid-state digital electronics
- Plug port detection
- Adjustable nuisance trip dampening
- Configurable IAW® self-diagnostics
- Min/Max process values memory
- 3-year warranty
- Provide a SFF = 98.8

**PROCESS DISPLAY MODULE**

The One Series Safety Transmitter process display module features a large, easy-to-read back-lit LCD display, showing the process variable and the health status of the instrument. (See Display Features for a complete description.) Set point, deadband and minimum/maximum process values can be easily accessed from the front of the unit after the locking cover is removed. Programming and interrogating the One Series Safety Transmitter is done through two buttons on the faceplate, providing easy setup and an added level of security from hackers and tampering. No remote hand-held programming device is required.

**HIGH-CAPACITY SAFETY RELAY OUTPUT**

The One Series Safety Transmitter model 2SLP incorporates a Safety Relay Output (SRO) to provide a high-capacity switch rating suitable for direct connection to the final element. The SRO may be used to provide an emergency shutdown signal locally, at the point of measure, to external equipment such as a motor control center (MCC), pilot valve or electrically actuated valve positioner. The state of the SRO (open or closed) may be monitored with a logic solver using the SRO Status output.



Shown with spring-loaded RTD sensor for thermowell mounting



Shown with differential pressure sensor



Shown with gage pressure sensor



Shown with dual seal and gage pressure sensor



## APPLICATION VERSATILITY

For alarm and shutdown switching applications, there is no better choice than the *One Series* family of electronic transmitter-switches from United Electric Controls. Measuring gauge pressure, differential pressure or temperature, the extremely rugged and reliable *One Series* takes all of the guess-work out of monitoring process variables to prevent injury, loss and downtime. With its large digital display, fully-adjustable deadband, and 100% solid-state design, the *One Series* is the obvious choice for plant upgrades and new construction projects. A built-in microprocessor includes digital repeatability and intelligent self-diagnostics, offering plant operators an extremely reliable and smart protection device.

Proven in use in literally thousands of diverse applications, UE's explosion-proof *One Series* models extend this revolutionary switching technology to Zone 1 (Division 1) areas.

Here are just a few applications:

- Safety systems – meets the requirements of SIL 2 for random integrity at HFT = 0, SIL 3 for random integrity at HFT = 1 and SIL 3 for systematic capability.
- FMEDA report available upon request
- Pumps and compressors – start/stop, emergency shutdown
- Lubricating oil monitoring – sump temperature, bearing pressure, predictive maintenance
- Hydraulic oil pressure – high pressure monitoring, emergency shutdown, low pressure alarm
- Filter monitoring – change indication, proving flow



exida<sup>®</sup> is a registered trademark of exida Consulting LLC.



One Series Safety Transmitters are shown mounted on Gas Processing Units that provide SIL 2 SIF pressure monitoring for natural gas separation skids

**SPECIFICATIONS**

**Power input /**

**Switch output:**

<b>Voltage and Current Maximum Ratings</b>			
<b>Signal Name</b>	<b>2SLP47</b>	<b>2SLP48</b>	<b>2SLP49</b>
Power Supply	2-wire 20-40 VDC @ 4-20 mA (Loop or Fixed Current)		
Safety Relay Output	12-250 VAC @ 5 mA-5 A	0-30 VDC @ 6 A, 1.8 A Pilot Duty	0-130 VDC @ 2.5 A, Q150 <sup>1</sup> Pilot Duty
With Relay Monitor Enabled	12-250 VAC @ 5 mA-5 A	10-30 VDC @ 5 mA-6 A	10-130 VDC @ 5 mA-2.5 A
Temperature Derating	1% per °C above 25°C		
SRO Status	30 VDC @ 20 mA		
IAW Output	30 VDC @ 20 mA		
	<sup>1</sup> Q150 Pilot Duty: 2.5 A (Continuous Current), 0.55 A (Make or Break), 69 VA		

**Accuracy:** 0.5% of full range span, at room temperature

**Repeatability:** 0.1% of full range span

**Ambient operating temperature range:**

	<b>Approved Ambient Operating Temperature Range</b>			
	<b>cULus (Division System)</b>		<b>cULus &amp; ATEX (Zone System)</b>	
2SLP	-40°F (-40°C)	158°F (70°C)	-40°F (-40°C)	158°F (70°C)

**Display operating temperature range:** 10°F (-12°C) 158°F (70°C)



### SPECIFICATIONS (CONTINUED)

**Long-term stability:** ±0.25% of range/year maximum

**Temperature drift:** 0.03% of full scale per °C (0.06% for the K10 range)  
Compensated temperature range for P10, K10 range is -20°C to 50°C

**Display response time:** 400 mS (2.5 Hz)

**Transient filtering:** Programmable time constants between 250 mS and 2 seconds in 2X increments

**Diagnostics (IAW®):** Open or shorted sensor; plugged port; power supply out of range; over and under-range conditions; microprocessor faults/failure; keypad short; switch fault

**Control modes:** Field-configuration for SRO switch action with programmable manual reset

Mode	Action	Fault
Open Rise	Open on rising media	Open
Open Fall	Open on falling media	Open
Window	Open outside window	Open

**Analog output:** Compliant to NAMUR NE 43 4-20 mA output, 360 ohms max. at 24 VDC, Field scalable, 2:1 turn down. Various faults are indicated at ≤3.6 mA. See installation manual for details.

**Analog output response time:** 250 mS maximum with Filter set to OFF, pressure models only

**Safety Relay Output Set point & deadband:** User-configured, 100% adjustable over entire sensor operating range, deadband of 0 is undefined

**Status Outputs:**  
**SRO Status** - 30 VDC @ 20 mA Maximum  
**IAW Output** - 30 VDC @ 20 mA Maximum

**Switch response time:** "Change-of-output" response ≤ 100 mS (for detection of full step change and change of output state, Filter feature off)

**Enclosure:** Type 4X/IP66 certified polyester painted aluminum alloy 360, vented for ranges P08-P14

**Faceplate:** UV-resistant pressure sensitive keypad and display overlay

**Cover:** Polyester painted aluminum with tempered glass insert

**Conduit:** 3/4" NPT female aluminum casting

**SPECIFICATIONS (CONTINUED)**

<b>Display:</b>	<p>Backlit</p> <ul style="list-style-type: none"> <li>• Local 4 digit x 0.5" LCD</li> <li>• IAW® (I Am Working) status</li> <li>• Process variable</li> <li>• Units of measure</li> <li>• Switch status</li> </ul> <ul style="list-style-type: none"> <li>• Latch status</li> <li>• Set point value</li> <li>• Deadband value</li> <li>• Min/Max values</li> <li>• Fault codes</li> </ul>
<b>Memory:</b>	Programming and data protected by non-volatile EEPROM
<b>Sensors:</b>	<p><b>Gauge Pressure</b> – 316L stainless steel, welded diaphragm, 1/2" NPT (female) process connection, micro-machined piezo-resistive strain gauge silicon element, 0.25 ml silicone oil fill. Maximum media temperature: -40 to 257°F (-40 to 125°C)</p> <p><b>Differential Pressure</b> - 316L stainless steel, welded diaphragms, 1/4" NPT (male) process connections, piezo-resistive strain gauge silicon element, silicone oil fill. Maximum media temperature: -40 to 257°F (-40 to 125°C)</p> <p><b>Temperature</b> – 316 stainless steel 0.25" OD sheath containing a 100 ohm 4-wire platinum RTD element available with epoxy fill (local low temp) or powder fill (remote high temp). Media temperature limits: -328 to 1000°F, intermittent to 1100°F (-200 to 538°C, int. to 593°C) for TH and TT ranges -40 to 500°F (-40 to 260°C) for TR and TL ranges</p>
<b>Vacuum:</b>	All pressure sensors withstand deep vacuum with no calibration effects. Two compound vacuum ranges are available-P06 and P08 (see page 8).
<b>EMI/RFI:</b>	Compliance to CE EMC requirements: EN 61000-6-2, EN 61000-6-4
<b>Emission:</b>	EN 61000-6-4 Class A
<b>Immunity:</b>	<p>EN 61000-4-2 Immunity to Electrostatic Discharge</p> <p>EN 61000-4-3 Immunity to Continuous Radiated Disturbances</p> <p>EN 61000-4-4 Immunity to Electrical Fast Transients</p> <p>EN 61000-4-5 Immunity to Surges</p> <p>EN 61000-4-6 Immunity to Continuous Conducted Disturbances</p> <p>EN 61000-4-11 Immunity to Voltage Dips and Interruptions</p>
<b>Weight:</b>	4.5 - 6.0 lbs (2.0 - 2.7 kg)
<b>Shock:</b>	per MIL-STD-810G method 516.6 – when device is subjected to 15 g (10 mSec) and 40 g (6 mSec); 3 drops/axis Effects: less than +/- 0.40% of range
<b>Vibration:</b>	per IEC 61298-3 (field and pipeline applications with high vibration level, 10-1000 Hz range, 0.014" displacement peak amplitude, 5 g acceleration amplitude) Effects: less than +/- 0.40% of range

IAW® is a registered trademark of United Electric Controls Co. Specifications subject to change without notice



## HOW TO ORDER

Build a part number by selecting the model, sensor and options from the tables below.

Model	Description	Zone			Division	
		0	1	2	1	2
2SLP47	2-wire loop-powered or 24 VDC fixed current power supply, 4-20 mA analog output, programmable solid-state relay rated at 12-250 VAC @ 5 mA-5 amperes, 2 status switch outputs each rated at 30 VDC @ 20 mA maximum	X	✓	✓	✓	✓
2SLP48	2-wire loop-powered or 24 VDC fixed current power supply, 4-20 mA analog output, programmable solid-state relay rated at 30 VDC @ 6 amperes (1.8 A pilot duty rating), 2 status switch outputs each rated at 30 VDC @ 20 mA maximum	X	✓	✓	✓	✓
2SLP49	2-wire loop-powered or 24 VDC fixed current power supply, 4-20 mA analog output, programmable solid-state relay rated at 130 VDC @ 2.5 amperes (Q150 pilot duty rating), 2 status switch outputs each rated at 30 VDC @ 20 mA maximum	X	✓	✓	✓	✓

Example: 2SLP47 P15-M041

Sensor	Pressure Operating Range <sup>1</sup> + display resolution					Maximum Over Range <sup>2</sup>	
Gauge pressure, piezo-resistive strain gage, silicone oil fill, 316L stainless wetted materials, 1/2" NPT (female) process connection, displayed as shown.							
P06	-14.7 to 30 psig	831.1" wc	2068 mbar	206.8 KPa	2.109 kg/cm <sup>2</sup>	60 psig	4137 mbar
P08	-14.7 to 100 psig	2770" wc	6895 mbar	689.5 KPa	7.031 kg/cm <sup>2</sup>	200 psig	13,8 bar
P10	0-5.00 psig	138.5 "wc	344,7 mbar	34.47 KPa	0.352 kg/cm <sup>2</sup>	10 psig	690 mbar
P11	0-15.00 psig	415.5 "wc	1034 mbar	103.4 KPa	1.055 kg/cm <sup>2</sup>	30 psig	2068 mbar
P12	0-30.00 psig	831.1 "wc	2068 mbar	206.8 KPa	2.109 kg/cm <sup>2</sup>	60 psig	4137 mbar
P13	0-50.00 psig	1385 "wc	3447 mbar	344.7 KPa	3.516 kg/cm <sup>2</sup>	100 psig	6895 mbar
P14	0-100.0 psig	2770 "wc	6895 mbar	689.5 KPa	7.031 kg/cm <sup>2</sup>	200 psig	13,8 bar
P15	0-300.0 psig	NA	20,68 bar	2068 KPa	21.09 kg/cm <sup>2</sup>	600 psig	41,4 bar
P16	0-500.0 psig	NA	34,47 bar	3447 KPa	35.16 kg/cm <sup>2</sup>	1000 psig	68,9 bar
P17	0-1000 psig	NA	68,95 bar	6895 KPa	70.31 kg/cm <sup>2</sup>	2000 psig	137,9 bar
P18	0-3000 psig	NA	206,8 bar	20.68 MPa	210.9 kg/cm <sup>2</sup>	6000 psig	413,7 bar
P19	0-4500 psig	NA	310,3 bar	31.03 MPa	316.4 kg/cm <sup>2</sup>	9000 psig	620,5 bar
P20	0-6000 psig	NA	413,7 bar	41.37 MPa	421.9 kg/cm <sup>2</sup>	12000 psig	827,4 bar



## HOW TO ORDER CONT.

Sensor	Pressure Operating Range <sup>1</sup> + display resolution				
Differential pressure, piezo-resistive strain gage, silicone oil fill, 316L stainless wetted materials, 1/4" NPT (male) process connections, displayed as shown.					
K10	0-5.000 psid	138.5 "wc	344,7 mbar	34.47 KPa	0.352 kg/cm <sup>2</sup>
K11	0-50.00 psid	1385 "wc	3447 mbar	344.7 KPa	3.516 kg/cm <sup>2</sup>
K12	0-100.0 psid	2770 "wc	6895 mbar	689.5 KPa	7.031 kg/cm <sup>2</sup>
K13	0-200.0 psid	NA	13,79 bar	1379 KPa	14.10 kg/cm <sup>2</sup>

Sensor	Maximum Over Range <sup>2</sup>		Maximum Working Pressure <sup>3</sup>	
K10	10 psid	690 mbar	50 psig	3447 mbar
K11	100 psid	6895 mbar	500 psig	34,47 bar
K12	200 psid	13,8 bar	1500 psig	103,4 bar
K13	400 psid	27,6 bar	1500 psig	103,4 bar

1 - The pressure range that the sensor will perform within specified tolerances.

2 - The maximum pressure that can be applied without affecting sensor performance.

3 - The maximum pressure that can be applied to both ports simultaneously without affecting sensor performance. Pressure on the "H" sensor port must be ≥ pressure on the "L" sensor port.

Sensor	Temperature Range	Description (see page 13 for sensor drawings)
Temperature – 4-wire RTD, 100 Ω platinum, DIN 0.00385, 0.25" OD sensor sheath, 316 stainless steel construction		
TL1	-40 to 450°F/-40 to 232°C (See page 11 fitting options)	Local (stem) mounted rigid to enclosure, 4" sheath length
TL2		Local (stem) mounted rigid to enclosure, 6" sheath length
TL3		Local (stem) mounted rigid to enclosure, 10" sheath length
TR1		Remote mounted, 2.5" sheath, 6' MI fixed extension length
TRC		Remote mounted, 2.5" sheath, 1' to 30' MI extension length MUST BE SPECIFIED. USE OPTION W074 ONLY.
TH1	-40 to 1000°F/-40 to 538°C (See page 11 fitting options)	Remote mounted, 2.5" sheath, 6' MI fixed extension length
THC		Remote mounted, 2.5" sheath, 1' to 30' MI extension length MUST BE SPECIFIED. USE OPTION W074 ONLY.
TC1	-300 to 200°F/-184 to 93°C (See page 11 fitting options)	Remote mounted, 2.5" sheath, 6' MI fixed extension length
TCC		Remote mounted, 2.5" sheath, 1' to 30' MI extension length MUST BE SPECIFIED. USE OPTION W074 ONLY.
TTC	-40 to 900°F/-40 to 482°C (Example: TTC-NUN6-L 10.5)	Local (stem) spring-loaded mount, NUN connection lengths: 4" – 10" in 1" increments, variable sheath (L) length up to 60", BOTH MUST BE SPECIFIED. Refer to drawing on page 13. Thermowell required, see page 11.
Thermowells and fittings are shown on page 11.		



### OPTION CODES

**QC1** Certificate of Conformance provides calibration verification for the switch set points and the 4-20 mA output using 3-point data collection for pressure and temperature models

**M041** Dual Seal - Provides secondary process seal for all pressure models

**M201** Factory programmed set point, deadband and switch mode

**(For Open on Rise or Open on Fall modes, all 3 settings are required at time of ordering - see example below)**

Set Point <sup>1</sup>	Deadband <sup>1</sup>	Switch Mode
40.00	25.00	Open on rise

**(For window mode all 4 settings are required at time of ordering - see example below)**

Set Point High <sup>1</sup>	Deadband High <sup>1</sup>	Set Point Low <sup>1</sup>	Deadband Low <sup>1</sup>
60.00	12.00	18.00	10.00

**M270** Display units, degrees C for temperature models

**M275** Display units, inches of water column

**M276** Display units, bar or mbar

**M277** Display units, kPa or MPa

**M278** Display units, kg/cm<sup>2</sup>

**M444** Paper tag

**M446** Stainless steel tag

**M449** Mounting bracket for pipe or wall. Use part number 6361-704 if ordered separately. See page 12 for additional information.

**M550** Oxygen cleaning service

**W073** 1/2" NPT male compression fitting for use with all TL and TR sensors, see page 11 for additional information

**W074** 1/2" NPT male union connector for use with all TR, TH and TC sensors

**W081** Thermowell adapter - Adapts 3/8" Thermowell to 1/4" sensor sheath. See details on page 11

**W930** 1/2" NPT male to G1/2 male adapter for use with gauge pressure sensors P06-P20. Use part number 6361-762 if ordered separately.

**W932** 1/4" NPT female to G1/2 male adapter for use with differential pressure sensors K10-K13. Use part number 6361-763 if ordered separately (2 required)

<sup>1</sup>Note: Four digits must be entered for each set point and deadband. Please refer to the display resolution chart on pages 8 & 9 for the correct number of decimal places allowed for the sensor range and units of measure selected.

## TEMPERATURE SENSORS AND FITTINGS COMPATIBILITY CHART

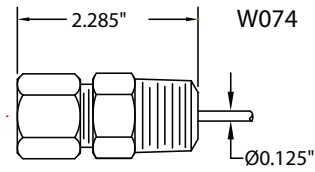
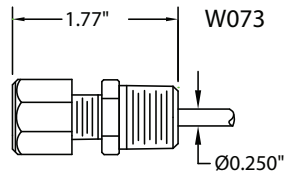

Model (Table 1)	<b>W073</b> 1/2" NPT compression fitting with ferrule to fit 0.25" sensor sheath	<b>W074</b> 1/2" NPT union connection to fit 0.125" sensor extension cable
2SLP	TLx	TRx, THx, TCx

### Thermowell Adapter Option W081

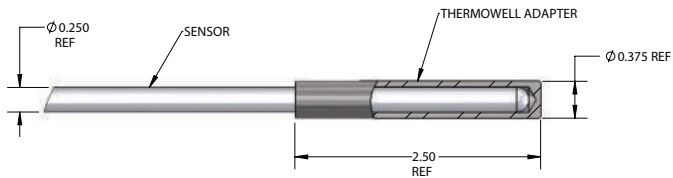

### Thermowell

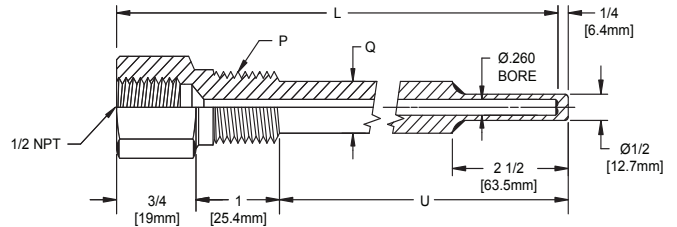

### Fittings for Thermowells

Thermowell UE Part #	Length (L) Inches	P (NPT)	Q	U	Local Temperature Sensors w/ 0.25" Sensor Sheath <sup>1</sup>			Remote Temperature Sensors w/ 0.125" Diameter MI Cable <sup>1</sup>
					TL1 (4")	TL2 (6")	TL3 (10")	TR, TH & TC
1S260L2.5-316	2.5	1/2	5/8	1	W073	W073	W073	W074
1S260 L4-316	4	1/2	5/8	2.5	NA	W073	W073	W074
1S260 L4.5-316	4.5	1/2	5/8	3	NA	W073	W073	W074
1S260 L5.5-316	5.5	1/2	5/8	4	NA	NA	W073	W074
1S260 L6-316	6	1/2	5/8	4.5	NA	NA	W073	W074
1S260 L6.5-316	6.5	1/2	5/8	5	NA	NA	W073	W074
1S260 L9-316	9	1/2	5/8	7.5	NA	NA	NA	W074
1S260 L9.5-316	9.5	1/2	5/8	8	NA	NA	NA	W074
1S260 L12-316	12	1/2	5/8	10.5	NA	NA	NA	W074
1S260 L15-316	15	1/2	5/8	13.5	NA	NA	NA	W074
1S260 L18-316	18	1/2	5/8	16.5	NA	NA	NA	W074
1S260 L24-316	24	1/2	5/8	22.5	NA	NA	NA	W074
2S260L2.5-316	2.5	3/4	3/4	1	W073	W073	W073	W074
2S260 L4-316	4	3/4	3/4	2.5	NA	W073	W073	W074
2S260 L6-316	6	3/4	3/4	4.5	NA	NA	W073	W074
2S260 L9-316	9	3/4	3/4	7.5	NA	NA	NA	W074
2S260 L12-316	12	3/4	3/4	10.5	NA	NA	NA	W074
2S260 L15-316	15	3/4	3/4	13.5	NA	NA	NA	W074
2S260 L18-316	18	3/4	3/4	16.5	NA	NA	NA	W074
2S260 L24-316	24	3/4	3/4	22.5	NA	NA	NA	W074

## DIMENSIONAL DRAWINGS

### ENCLOSURE AND SENSOR DETAILS

Shown with gauge pressure sensor and Dual Seal option M041

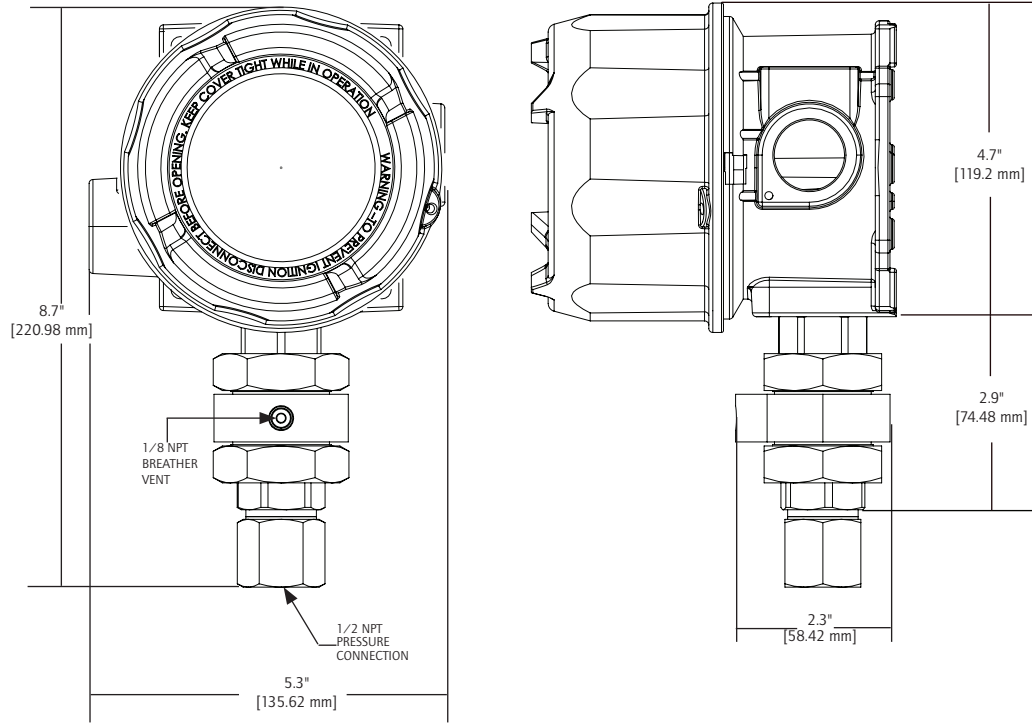

#### Wall or Pipe Mounting Bracket Option M449 or part #6361-704

WARNING: The One Series unit must be secured to a wall or pipe. *Do not use the sensor to support the instrument.* Contact UE Technical Support at 617-923-6977 or email at techsupport@ueonline.com.

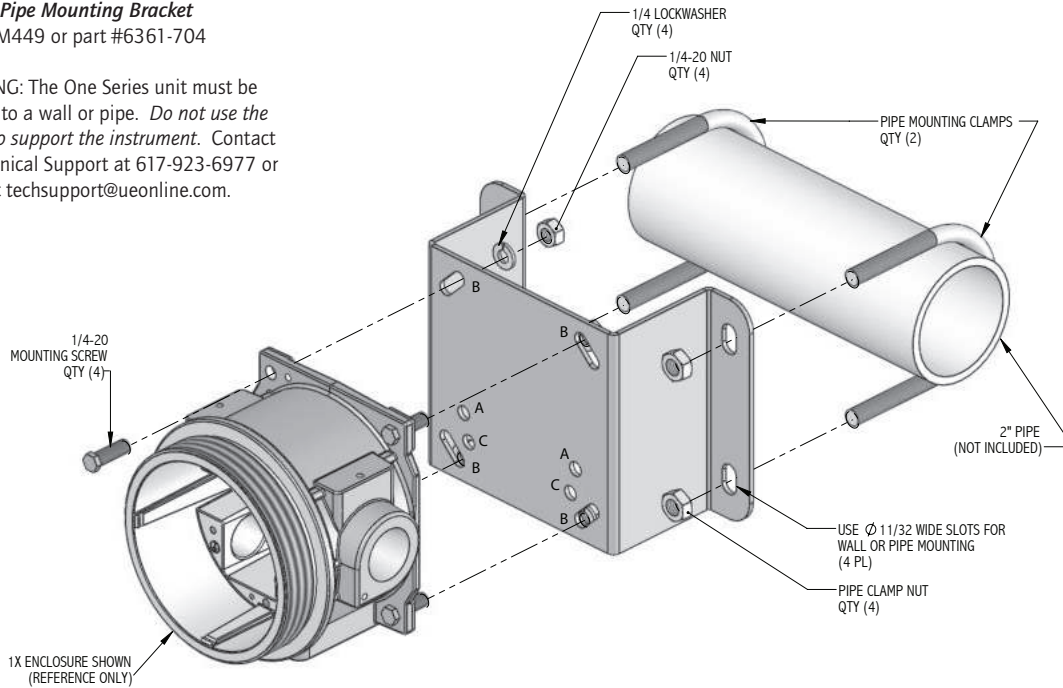

**DIMENSIONAL DRAWINGS (CONTINUED)**

**TEMPERATURE SENSORS**

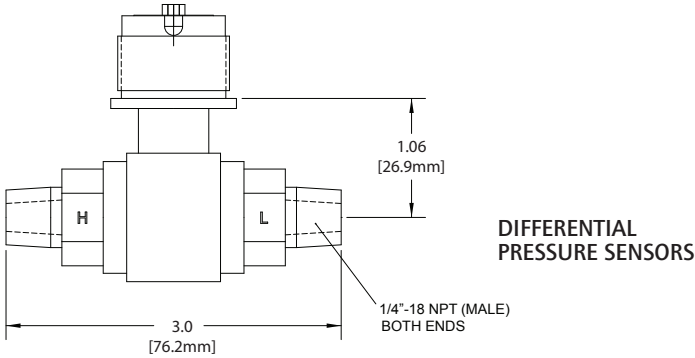
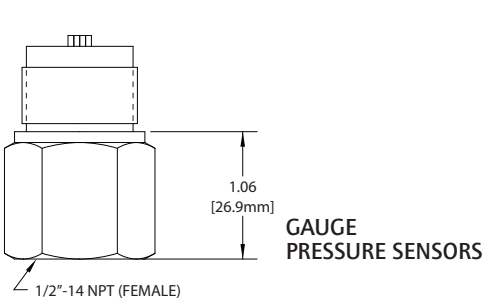
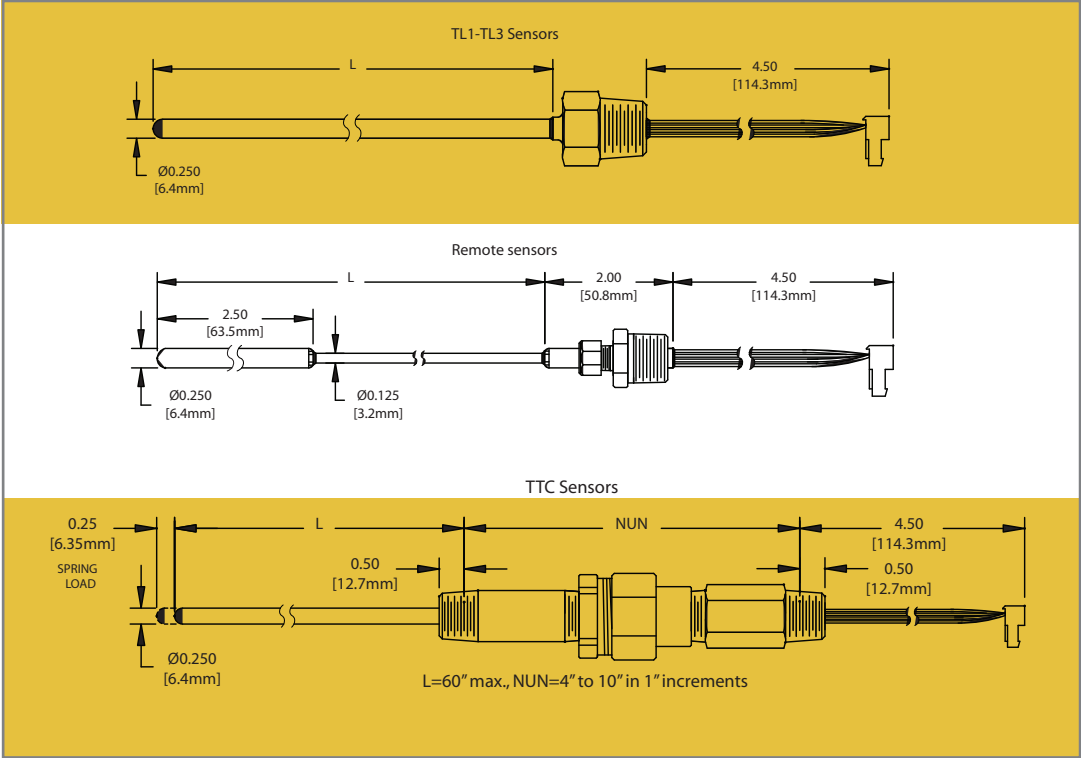



## APPROVALS & RATINGS

Model	N. America	Europe	International
	UL File# E226592 UL Listed, cUL Certified UL 50, 50E, 1203, 60079-0, 60079-1, 61010-1 CSA C22.2 No. 25, 30, 60079-0, 60079-1, 61010-1	European Union Directive 2014/34/EU EN 60079-0: 2012+A11:2013, EN 60079-1:2014, EN 60079-11:2012, EN 60079-31:2014	IECEx Scheme IEC 60079-0:2011, IEC 60079-1:2014-06, IEC 60079-11:2011, IEC 60079-15:2010, IEC 60079-31:2013
2SLP Explosion proof/ Flameproof	Class I, Groups A, B, C and D; Class II, Groups E, F, G; Class III Class I, Zone 1, AEx d IIC T3/T5** Class I, Zone 1, Ex d IIC	Certificate# DEMKO 09 ATEX 0813748X Rev. 6 II 2 G Ex db IIC T3/T5** II 2 D Ex tb IIIC T90°C Db -40°C≤Tamb≤70°C IP66	Certificate# IECEx UL 08.0017X Ex db IIC T3/T5** Gb Ex tb IIIC T90°C Db IP66 -40°C≤Tamb≤70°C

\*\*T3 for pressure sensor ranges P10-P16 only. T5 for all other models.  
 Specifications subject to change without notice.

## ADDITIONAL PRODUCTS FROM UE

### Vanguard Gas Detector – Toxic and Combustible Gas Detector

- WirelessHART Communication
- 5+ year battery life\*
- Field interchangeable toxic and combustible gas sensors
- Interoperable with existing WirelessHART networks and asset management systems (AMS)
- Easy calibration and operation
- Heavy duty design with Class 1, Div 1 & 2 hazardous location approvals

\*Affected by polling frequency



### 120 Series – Electro-Mechanical Pressure and Temperature Switch

- Certified for use in SIL 2 environments
- Explosion-proof line of pressure, differential pressure, and temperature models with wide selection of ranges, sensors and pressure connections
- UL, cUL, ATEX certified for hazardous locations
- Single or dual switch outputs
- Many available wetted materials
- Internal or external set point adjustment



### One Series for Division 1 & 2 (Zone 0, 1, 2)

- Easy and secure programming via local keypad or read-only remote HART® 7 communications
- Money-saving drop-in replacement for mechanical switches using the 2-wire switch-only version
- Achieve high reliability through IAW™ self-diagnostics and separate alarm contact
- Gain Asset Management data through HART 7 reporting
- A complete, flexible solution – 4-20mA for trending plus 2 relays for local switching - all accessible via HART® 7 Communications Protocol



### 100 Series – Pressure, Vacuum, Differential Pressure and Temperature Switch

- Certified for use in SIL 2 environments
- Single Switch Output
- Epoxy Coated and Gasketed Cast Aluminum Enclosure Type 4X
- Tamper-Resistant Set Point "Lock"
- Heat Trace and Freeze Protection Thermostats
- Proof Pressures to 10,000 psi (689,5 bar)



### Temperature Sensors

Rugged RTDs and thermocouples for process and energy applications, available with Nema 4X and explosion-proof heads to match heat-trace, turbine, combustion, and stack-emission applications



## RECOMMENDED PRACTICES AND WARNINGS

United Electric Controls Company recommends careful consideration of the following factors when specifying and installing UE pressure and temperature units. Before installing a unit, the Installation and Maintenance instructions provided with unit must be read and understood.

- To avoid damaging unit, proof pressure and maximum temperature limits stated in literature and on nameplates must never be exceeded, even by surges in the system. Operation of the unit up to maximum pressure or temperature is acceptable on a limited basis (e.g., start-up, testing) but continuous operation must be restricted to the designated adjustable range. Excessive cycling at maximum pressure or temperature limits could reduce sensor life.
- A back-up unit is necessary for applications where damage to a primary unit could endanger life, limb or property. A high or low limit switch is necessary for applications where a dangerous runaway condition could result.
- The adjustable range must be selected so that incorrect, inadvertent or malicious setting at any range point cannot result in an unsafe system condition.
- Install unit where shock, vibration and ambient temperature fluctuations will not damage unit or affect operation. When applicable, orient unit so that moisture does not enter the enclosure via the electrical connection. When appropriate, this entry point should be sealed to prevent moisture entry.
- Unit must not be altered or modified after shipment. Consult UE if modification is necessary.
- Monitor operation to observe warning signs of possible damage to unit, such as drift in set point or faulty display. Check unit immediately.
- Preventative maintenance and periodic testing is necessary for critical applications where damage could endanger property or personnel.
- Electrical ratings stated in literature and on nameplate must not be exceeded. Overload on a switch can cause damage, even on the first cycle. Wire unit according to local and national electrical codes, using wire size recommended in installation sheet.
- Do not mount unit in ambient temp. exceeding published limits.

## LIMITED WARRANTY

Seller warrants that the product hereby purchased is, upon delivery, free from defects in material and workmanship and that any such product which is found to be defective in such workmanship or material will be repaired or replaced by Seller (Ex-works, Factory, Watertown, Massachusetts. INCOTERMS); provided, however, that this warranty applies only to equipment found to be so defective within a period of 36 months from the date of manufacture by the Seller. Seller shall not be obligated under this warranty for alleged defects which examination discloses are due to tampering, misuse, neglect, improper storage, and in any case where products are disassembled by anyone other than authorized Seller's representatives. EXCEPT FOR THE LIMITED WARRANTY OF REPAIR AND REPLACEMENT STATED ABOVE, SELLER DISCLAIMS ALL WARRANTIES WHATSOEVER WITH RESPECT TO THE PRODUCT, INCLUDING ALL IMPLIED WARRANTIES OF MERCHANTABILITY OR FITNESS FOR ANY PARTICULAR PURPOSE.

## LIMITATION OF SELLER'S LIABILITY

SELLER'S LIABILITY TO BUYER FOR ANY LOSS OR CLAIM, INCLUDING LIABILITY INCURRED IN CONNECTION WITH (I) BREACH OF ANY WARRANTY WHATSOEVER, EXPRESSED OR IMPLIED, (II) A BREACH OF CONTRACT, (III) A NEGLIGENT ACT OR ACTS (OR NEGLIGENT FAILURE TO ACT) COMMITTED BY SELLER, OR (IV) AN ACT FOR WHICH STRICT LIABILITY WILL BE INPUTTED TO SELLER, IS LIMITED TO THE "LIMITED WARRANTY" OF REPAIR AND/OR REPLACEMENT AS SO STATED IN OUR WARRANTY OF PRODUCT. IN NO EVENT SHALL THE SELLER BE LIABLE FOR ANY SPECIAL, INDIRECT, CONSEQUENTIAL OR OTHER DAMAGES OF A LIKE GENERAL NATURE, INCLUDING, WITHOUT LIMITATION, LOSS OF PROFITS OR PRODUCTION, OR LOSS OR EXPENSES OF ANY NATURE INCURRED BY THE BUYER OR ANY THIRD PARTY.

*UE specifications subject to change without notice.*

FOR A LIST OF OUR INTERNATIONAL AND DOMESTIC  
REGIONAL SALES OFFICES PLEASE VISIT OUR  
WEBPAGE [WWW.UEONLINE.COM](http://WWW.UEONLINE.COM)



UNITED ELECTRIC  
CONTROLS

180 Dexter Avenue, P.O. Box 9143  
Watertown, MA 02471-9143 USA  
Telephone: 617 926-1000 Fax: 617 926-2568  
[www.ueonline.com](http://www.ueonline.com)